

Angular grab bar

- Three-arm fixed grab bar for fixing to the wall.
- Aluminum and supports in AISI 304 stainless steel, white nylon finish.
- With four anchor points.
- Suitable for support in bathrooms, wc-bidet, showers and baths.
- Designed for people adapted to people with reduced mobility.

TECHNICAL DATA

- Made of aluminum covered in white ABS with permanent antibacterial protection.
- Supports stainless steel AISI 304.
- Dimensions: 1150 height x 500 width x 70 depth.
- Vertical arm of 1150 mm and horizontal arm of 500 mm.
- Bars of Ø34 mm.
- Thickness of 1,2 mm.
- Screws included.

SUGGESTED TEXT FOR PRESCRIPTION

NOFER angular fixed grab bar in aluminum covered with white ABS with permanent antibacterial protection. Dimensions: 1150 height x 500 width x 70 depth. Ø34 mm bars.

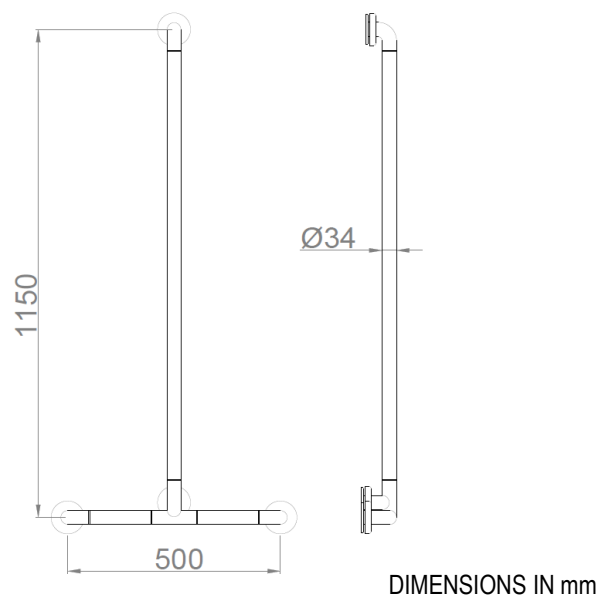
TECHNICAL DRAWING

NOFER S.L.
 Avenida de la fama, 118
 08940 · Cornellà de Llobregat (Barcelona)
 Tel +34 934 742 423 · Fax +34 934 743 548
 nofer@nofer.com · www.nofer.com

Related Products
