

Automatic electronic hand dryer with UVC leds

- High speed hand dryer with electronic sensor and UVC led lights.
- Anti-Bactericidal and virucidal properties.
- Surface mounted.
- Stainless steel housing with a satin matt finish. Polished (01851.UV.B) and white (01851.UV.W) versions also available.
- Ideal for public use and high traffic areas.
- Anti-vandal, robust design and construction.
- Smooth edges.
- In accordance with European safety directives (EC).

TECHNICAL DATA

- Housing made with one piece stainless steel AISI 304 (e=1.2mm)
 - Wall mounted. 4 drill holes. Fixing kit included (8mm).
 - Installation: wall mounted. Allow at least 20cm under the unit for the hand drying area.
 - Electronic infrared sensor with automatic cut off when hands are removed from the drying area.
 - UVC led lights that switch on when the hand dryer is activated.
 - Power led light: 10W.
 - Wavelength 240 nanometers.
 - Air temperature (environment): 40°C with 10cm range.
 - Universal type motor, no brushes (low maintenance).
 - Motor speed: 3500 r.p.m.
 - Air speed 305 km/h.
 - Total power: 800W
 - Motor power: 800W
 - Voltage/Frequency: 220-240 - 50/60Hz.
 - Electric insulation: Class I
 - Thermostat overheating resistance (automatic reset).
 - Double safety thermal fuse calibrated to 133°C.
 - Sensor range: 20cm.
 - Maximum consumption: 3.5A
 - Noise level @ 2 meters: 72 dBA.
 - Protection rating against water spray: IPX1.
 - Dimensions: 323x253x152mm (height x width x depth)
 - Package dimensions: 360x300x180mm (height x width x depth).
 - Net weight: 4.9Kg.
 - Gross weight inc.packaging: 5.3 Kg.
- Instructions for use: place hands under the unit in the drying area . The dryer will turn on automatically and turn off a few seconds after the hands are removed from the drying area.
- Estimated drying time: 10-12 seconds.
- Cleaning: we recommend cleaning the unit with a damp cotton cloth. A gently soap solution may be used. Then dry with a dry cloth.

SUGGESTED TEXT FOR PRESCRIPTION

NOFER hand dryer with UVC led light. AISI 304 stainless steel housing with a polished finish. Hot air operation with electronic sensor. 800W power with a temperature of 40°C. Motor speed 35000 r.p.m.

Dimensions: 323x253x152mm (height x width x depth).



INDELE Limited
 7 Bell Yard, London, WC2A 2JR
 t. 01256 976 821 | sales@indele.co.uk
 www.indele.co.uk | Company Reg. 10445602

Related Products

01851.B

01861.W

01851.W

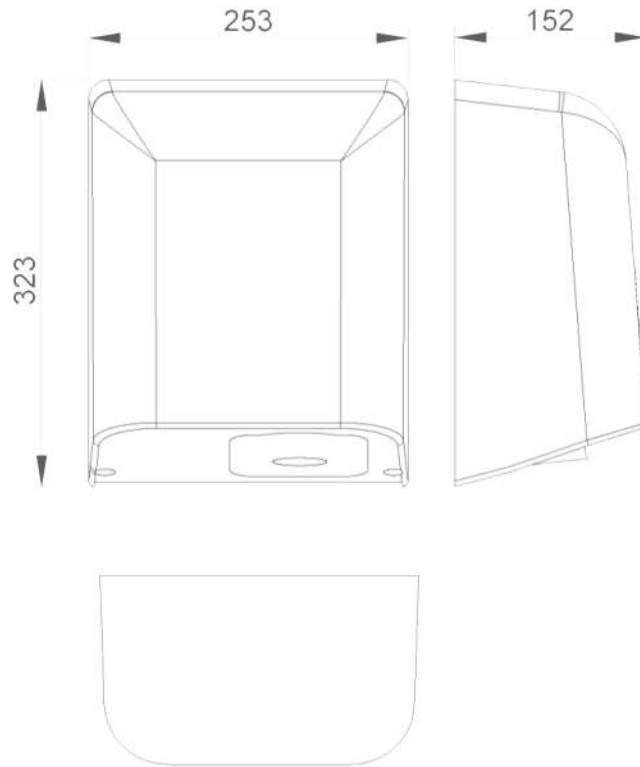

DRAWING



DIMENSIONS MM

INSTALLATION

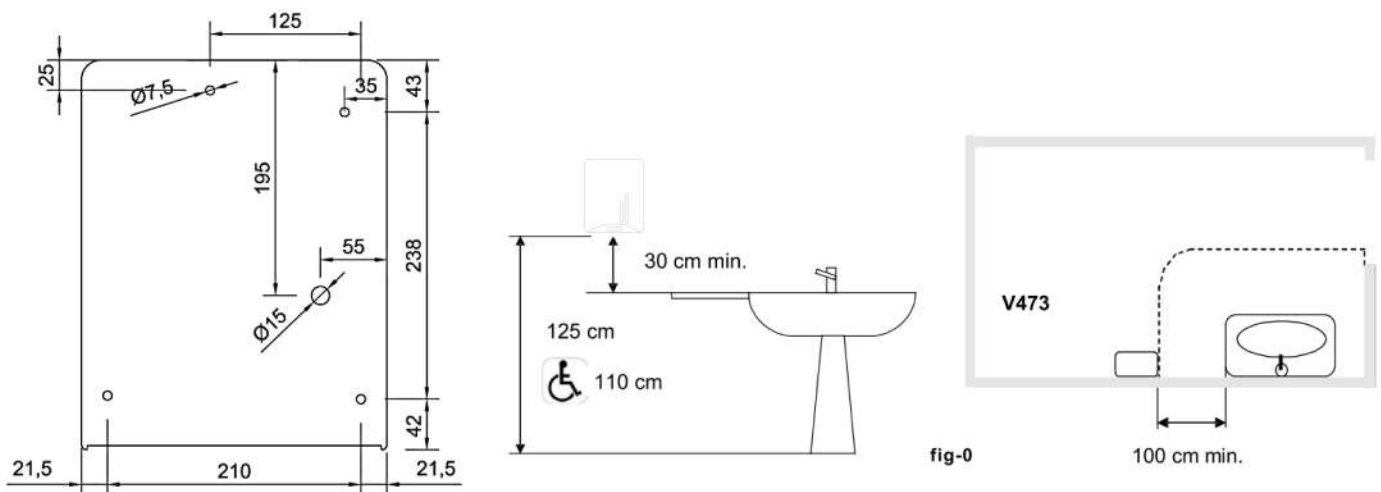
In high traffic washrooms, one unit per washbasin is advisable. In low traffic washrooms, one unit per 2-3 washbasins is sufficient. The wall fixing instructions for the unit are shown in the diagram below, fig-0. Where the unit is installed above marbel or shiny surfaces, increase the space between the base of the unit and the surface to 40cm.



INDELE Limited
 7 Bell Yard, London, WC2A 2JR
 t. 01256 976 821 | sales@indele.co.uk
 www.indele.co.uk | Company Reg. 10445602

