

Double hanger serie MONACO

- Double hanger made of polish chromed brass.
- Durability and resistance against rust and corrosion.
- Easy to install and clean.
- Suitable for public spaces.

TECHNICAL DATA

- Manufactured in polish chromed brass.
- Dimensions: 60 height x 100 width x 57 depth (mm).
- hidden fixings. Wall fixings included.

SUGGESTED TEXT FOR PRESCRIPTION

NOFER serie Monaco double hanger made of polish chromed brass. Dimensions: 60 height x 100 width x 57 depth (mm).

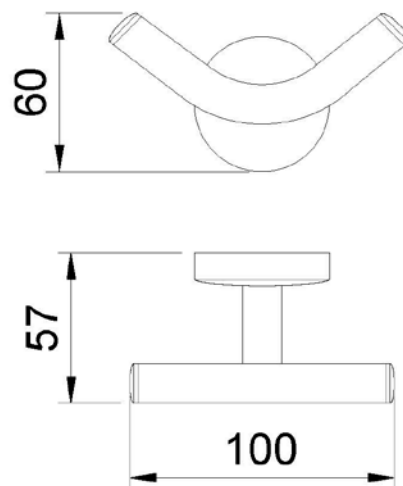
ESQUEMA DIMENSIONAL

DIMENSIONES EN mm



NOFER S.L.
 Avenida de la fama, 118
 08940 · Cornellà de Llobregat (Barcelona)
 Tel +34 934 742 423 · Fax +34 934 743 548
 export@nofer.com · www.nofer.com

Related Products



16370.B



16381.B



16372.B



16379.B



16374.B



16376.B