

Folding seat with backrest and two adjustable legs

- Folding seat with support for wall fixing.
- With two adjustable support legs .
- Designed for bathrooms adapted for people with reduced mobility.



COMPONENTS AND TECHNICAL DATA

- Made of white polypropylene with anti-bacterial protection.
  - Supports made of stainless steel AISI 304.
  - Maximum weight: 160 kg (with a suitable wall mounting).
  - Recommended installation height 45-50 cm seat area to finished floor.
- Maintenance : Stainless steel requires maintenance as dirt over time can damage the chrome (Cr) containing stainless steel. We recommend monthly cleaning with a specialized stainless steel product. Polypropylene should be cleaned with a cloth dampened with soapy water (soap), rinse and dry thoroughly with a soft cloth.

SUGGESTED TEXT FOR PRESCRIPTION

NOFER seat or equivalent, made of white polypropylene with anti-bacterial protection. With back and two adjustable support legs to the ground. Brackets AISI 304 stainless steel.



NOFER S.L.  
 Avenida de la fama, 118  
 08940 · Cornellà de Llobregat (Barcelona)  
 Tel +34 934 742 423 · Fax +34 934 743 548  
 export@nofer.com · www.nofer.com

DIMENSIONAL OUTLINE

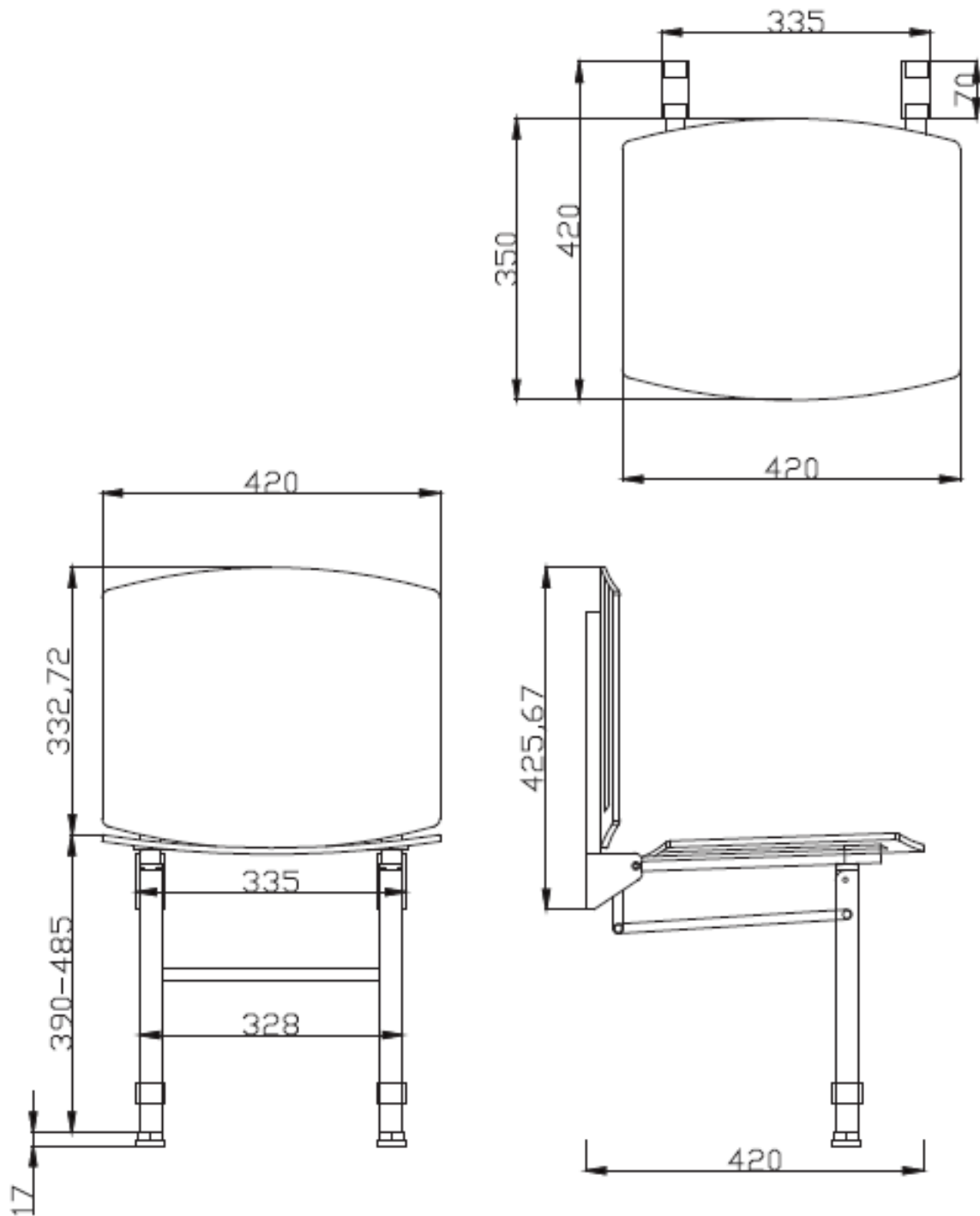

DIMENSIONS IN mm



NOFER S.L.  
 Avenida de la fama, 118  
 08940 - Cornellà de Llobregat (Barcelona)  
 Tel +34 934 742 423 - Fax +34 934 743 548  
 export@nofer.com - www.nofer.com